

UPB[®] BOARDS

made of Resvsta[®]

- **100% water-resistant**
- **Easy to process like wood**
- **customized color design**
- **Premium edge**
- **Thermoformable**
- **100% recyclable**



reddot design award
winner 2017



**Green
Product Award**

Winner 2018

CATEGORY ARCHITECTURE

Installation - Guidelines Facade Products from
UPB BOARDS



UPB[®] Boards made of Resvsta[®]



CONTENTS

1. BASIC INFORMATION / PROPERTIES _____	5
1. PROCESSING _____	7
3. SURFACE TREATMENT _____	9
4. UPB PRODUCTS _____	11
5. GENERAL INSTALLATION INFORMATION _____	13
6. CLEANING / CARE / REPAIR _____	29
7. FURTHER INFORMATION _____	30
8. LEGAL INFORMATION _____	31



GUARANTEE
on the
material

15 years

no swelling
no cracking
no splintering
no rotting

1. BASIC INFORMATION

PROPERTIES

The following basic properties must be observed when using UPB profiles for facades

Thermal properties

UPB profiles are made of thermoplastic material and therefore feature specific thermal properties.

The following points should be observed:

- Cutting and installation should be performed at a constant material temperature
- The thermal expansion must be noted during construction
- The values are higher for free expansion than for fixed screw connection
- Slight sagging of the profiles is possible owing to their natural composition
The sag can be in the range from 2 - 3 mm

Note:

One of the unique features of the UPB boards is their ecoplus³ technology, which reduces the force of thermal expansion to about 1/7 of conventional plastic boards. UPB boards made of Resysta can therefore be used with conventional fixing (as with wood for instance) so as to reduce the thermal expansion to a minimum.

Homogenous edge cross-section

The edges do not have to be laminated subsequently as these already have a homogeneous cross section. Further processing can be effected immediately after each cut. Edge glue is not required. The edges only have to be rounded or sanded lightly, if required. We recommend treating the edges if the surface is to undergo colouration.





2. PROCESSING

Processing

The products can be processed with any standard woodworking tools and machines. The machining options primarily include sawing, milling, drilling.

We recommend carbide-coated tools for circular saws and milling cutters.

Sanding

Common woodworking sandpaper can be used.

We recommend carbide-coated tools for circular saws and milling cutters.

Notes:

For unpainted surfaces use grain 24 to 60 in order to attain the structure.

Only use finer sandpaper (grain > 80) for removing dirt

Do not sand too deep, as otherwise the surfaces will lose their structure.

Sanding dust and milling cuttings must be collected separately. Do not mix with wood dust or burn. The collected waste can be reused and incorporated in new products.

Screwing / Gluing

The profiles can be glued with a wide range of adhesives and joined with all common screws.

This means special profiles such as end strips and angular profiles can be produced.

Thermoforming

Thermoforming of profiles is easily feasible due to the thermoplastic properties.

Please refer to the Tech Info brochure for more detailed information.



3. SURFACE TREATMENT

We recommend surface treatment of facades to serve protection against damage caused by UV, dirt and moisture. A number of different design options are also available.

Please note:

- Painting of the profiles is recommended before installation
- Do not paint or varnish under the influence of direct sunlight
- Due to technical conditions, sides and edges should be treated
- Treat UPB rear with primer
- Pretreatment of UPB surface with Resysta primer and smooth slightly afterwards

Cleaning / Preparation

Sand surfaces lightly with sandpaper (P100) to remove any scratches, signs of use or irregularities. Remove sanding dust and other dirt. The substrate must be dry, firm and free of dirt and separating substances.

Transparent coatings:

We recommend using Resysta products for transparent surfaces as transparent wood varnishes are permeable to water vapour and are therefore only moderately weather-proof. Resysta provides the following products, depending on wear and tear.

	Product		
Transparently coloured varnishes for decorative interior and exterior colour design, e.g. facades, fences, soffits. Water-based, quick-drying and easy to work with.	RBP	Primer / base coat	Surface pretreatment and sealing
	RCL coloured	Transparently coloured varnish	Colouration and painting
	RCL clear lacquer	Clear lacquer	Optionally creates additional abrasion protection
Transparent coloured stains with an additional 2-component clear lacquer for mechanically and chemically highly resistant interior and exterior surfaces, e.g. terrace floors and functional furniture. In the case of facades, the surface is graffiti resistant.	RBP	Primer / base coat	Surface pretreatment and sealing
	FVG	Transparent stain	For colouration
	RFS	2-component clear lacquer	For sealing and protection
Naturally transparently coloured oils that can be quickly and easily applied and refreshed due to simple handling. Exceptionally well-suited for easily accessible areas such as floors.	RTO	Transparent oil	Colouration and protection

Top coatings:

Resysta paints or standard aqueous and solvent-based products can be used here. Product selection depends on application area and requirements.



4. UPB PRODUCTS

The following products are recommended in the dimensions listed below or can be manufactured and supplied via our partners. Information on the maximum mounting distances and expansion joints can be found in the table.

The assembly must be adapted correspondingly in case of self-made and divergent products, sizes and forms. Assembly is the responsibility of the manufacturer. If you have any questions relating to technical support, please contact TREE PAL.

Product	Length mm	Width mm	Thickness mm
Rhombus profile 70x20	2420	70	20.00
Rhombus profile 110x20	2420	110	20.00
Rhombus profile TIGA 65x20	2420	65	20.00
Rhombus profile TIGA 90x20	2420	90	20.00
Tongue and groove profile 140x12	2400	140	12.00
Casing Board lintel formwork	2420	90	16.00
Casing Board lintel formwork	2420	160	16.00
Clapboard 600 x 300 x 8	600	300	8.00
Clapboard 900 x 300 x 8	900	300	8.00
Clapboard 1200 x 300 x 8	1200	300	8.00
Facade board STRAP 600 x 300 x 12	600	300	12.00
Facade board STRAP 900 x 300 x 12	900	300	12.00
Facade board STRAP 1200 x 300 x 12	1200	300	12.00

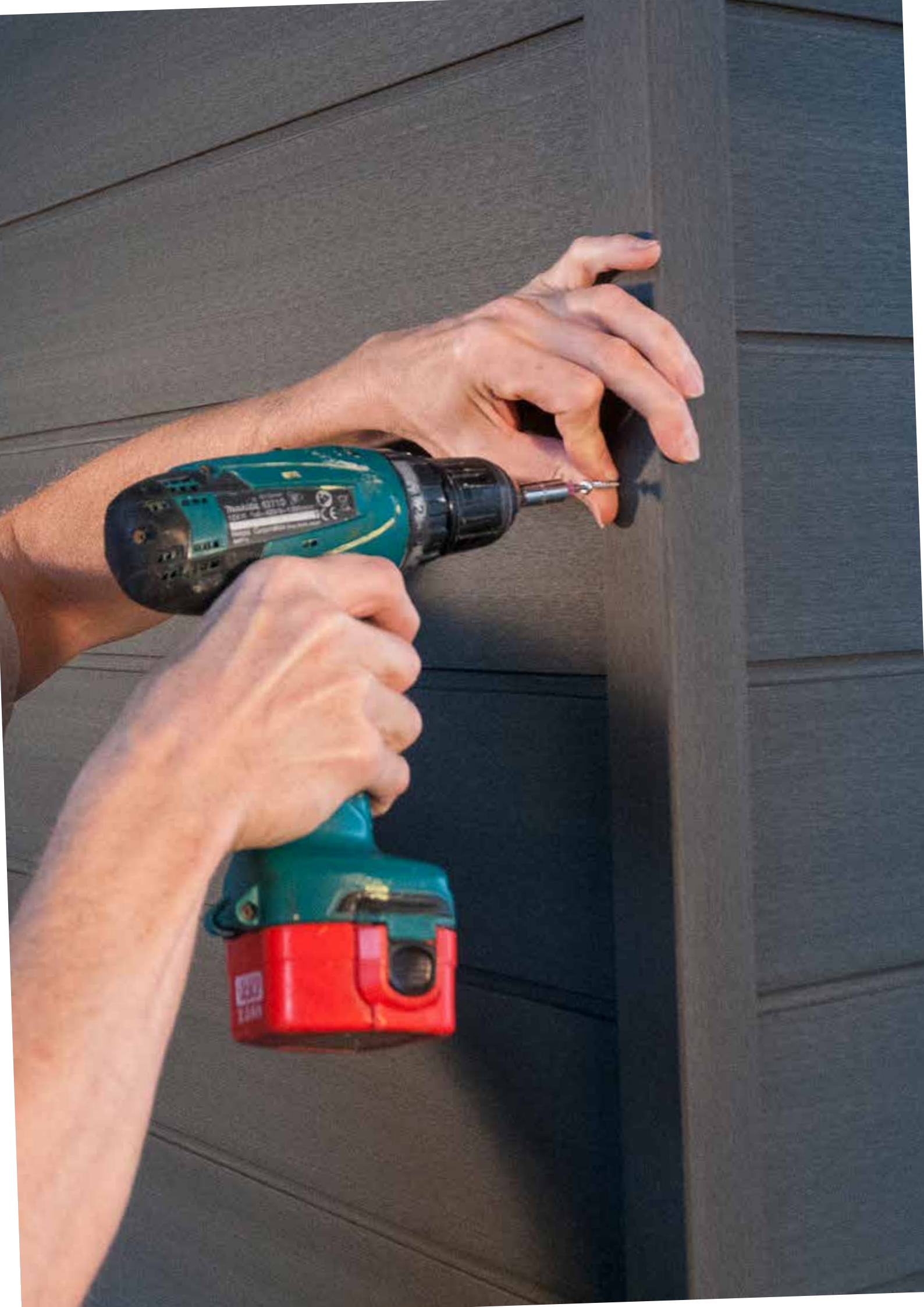

5. GENERAL INSTALLATION INFORMATION

Important information:

- All necessary DIN standards and regulations must be complied with
- The assembly must be carried out according to the general technical rules
- Only install as curtain-wall facing with air space



The back ventilation distance must be at least 20 mm and must not be constricted. The ventilation openings must be 20 mm wide continuously.

5.1 Substructure

- Depending on the products, the substructure must be realised vertically or horizontally
- The specified maximum substructure distances must be strictly complied with.
The distances are calculated centre / centre
- The substructure mounting depends on the substrate.
The fasteners must be chosen correspondingly
- The substructure must be aligned horizontally and vertically
- We primarily recommend aluminum substructures as this material meets the durability of UPB boards
- The corresponding technical rules must be observed for installation

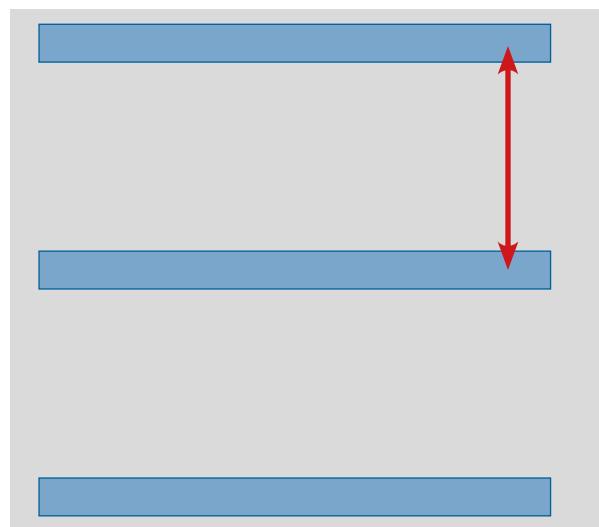
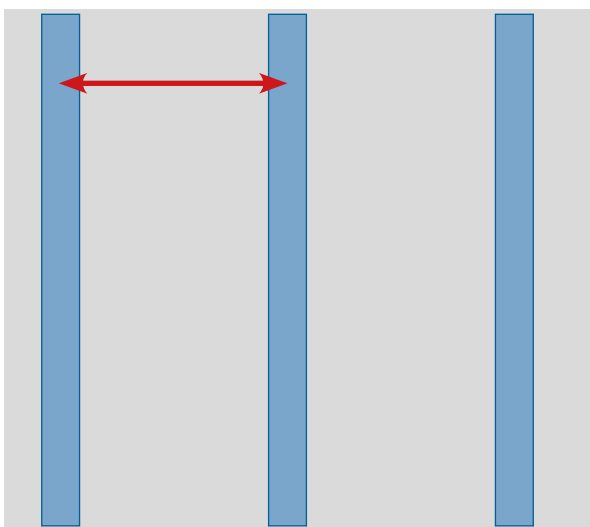

Lower edge spacing centre/centre

5.2 Important installation information

5.2.1 Maximum protrusion

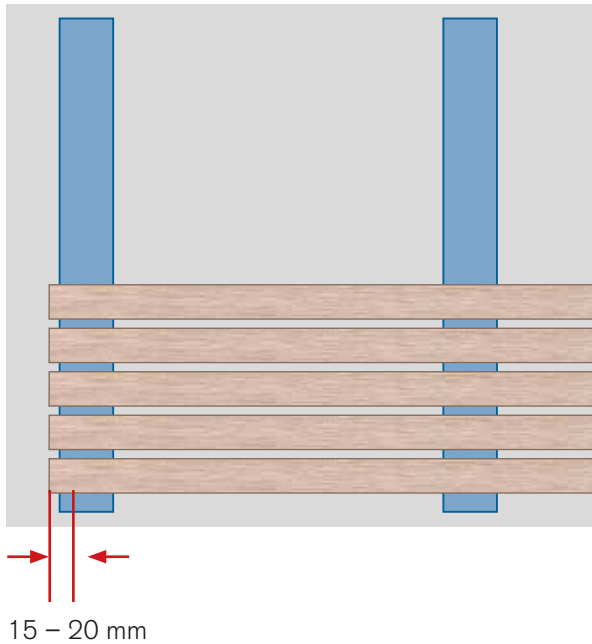

To avoid curvature upwards at the edge, limit the protrusion to the first fastening point to maximum 15 – 20 mm.

5.2.2 Joints

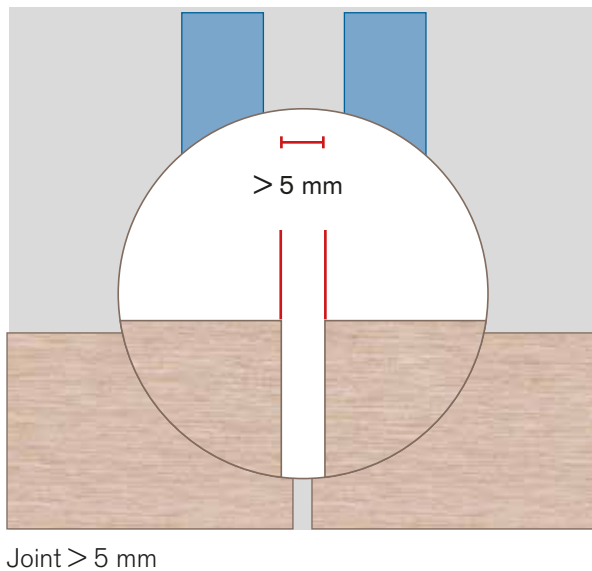

For visual reasons, a joint should generally be ensured between the profiles. This should be > 5 mm. A joint > 5 mm must be ensured at boundaries to other structures.

Note:

3 mm joint spacing must be factored into the planning for each 1 m profile length in case of free expansion. A maximum temperature difference of 50° is taken account of here.

5.3 Fasteners

Screws are normally used for fastening. Nails or other fasteners can also be used sometimes.

Notes:

- Choose fasteners to suit the application.
- Pay attention to resultant forces and tension/compression of the head
- Choose screw heads and fasteners that are large enough
- Tighten screws slowly
- Fasten screws flush
- Use suitable materials for outside areas (rustproof)

Choose screws appropriate for the substructure.

Note:

The sizes and lengths of the fasteners can vary, depending on the application. Fasteners suitable for the individual case must be chosen. These primarily depend on the substructure used.

5.4 Suggested mounting

5.4.1 Rhombus profile mounting

Rhombus profiles are generally installed horizontally. Vertical assembly is not recommended owing to inadequate drainage. For visual reasons, a staggered layout is recommended for the joints.

Product	Maximum lower edge spacing (centre/centre)	Joint	Note
Rhombus profile 70x20	350 mm	> 5 mm	Fastening 1 screw centre
Rhombus profile 110x20			Fastening 2 screws

Substructure / Protrusion

Lower edge distance maximum 350 mm

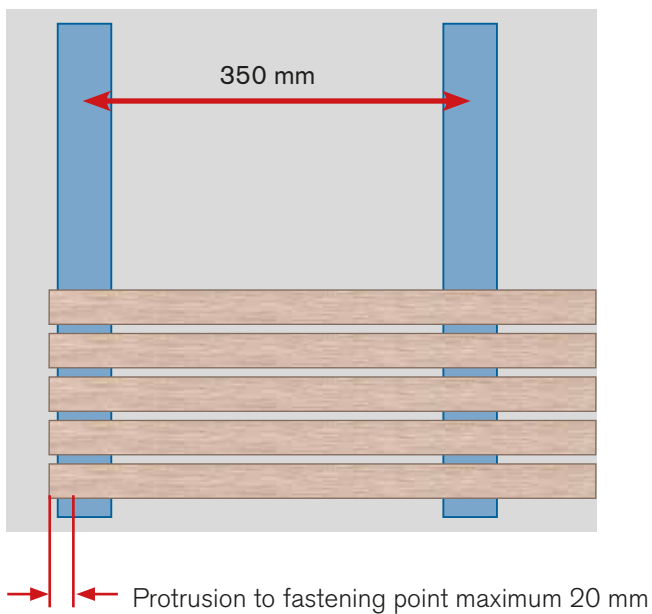

Installation

Profile screw connection 70 mm

Rhombus profile 70 mm
(Fastening 1 screw centre)

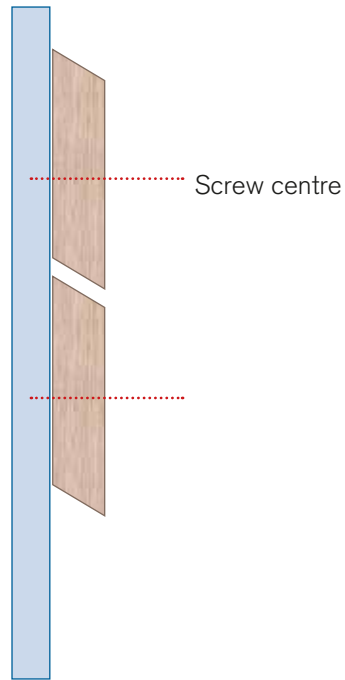

Profile screw connection 110 mm

Rhombus profile 110 mm
(Fastening with 2 screws)

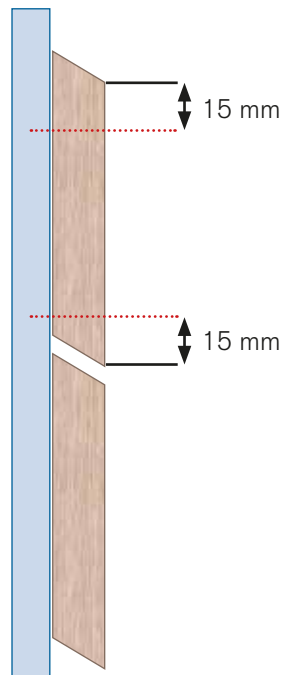

Note:

To attain a straight line during assembly, we recommend using spacers. For visual reasons, the joint should be > 5 mm in the longitudinal direction.

5.4.2 Rhombus TIGA system mounting

Rhombus profiles with the TIGA system are generally installed horizontally. Vertical assembly is not recommended owing to inadequate drainage. For visual reasons, a staggered layout is recommended for the joints.

With the TIGA system, a corresponding tongue and groove is milled using special milling cutters. The assembly is invisible with the TIGA system clips. The distances in the longitudinal direction are specified by the clip.

Product	Maximum lower edge spacing (centre/centre)	Joint	Fasteners
Rhombus profile TIGA 65x20	350 mm	System	TIGA system
Rhombus profile TIGA 90x20			

Substructure / Protrusion

Lower edge distance maximum 350 mm

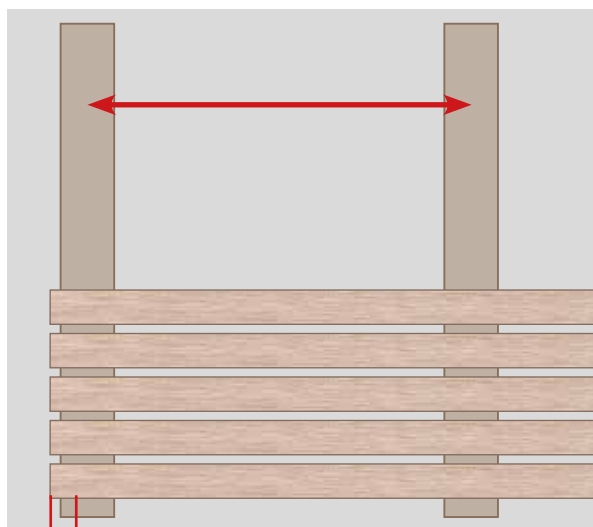

→ ← Protrusion to fastening point maximum 20 mm

Note:

Maximum protrusion to the first fastening point 20 mm.

Assembly

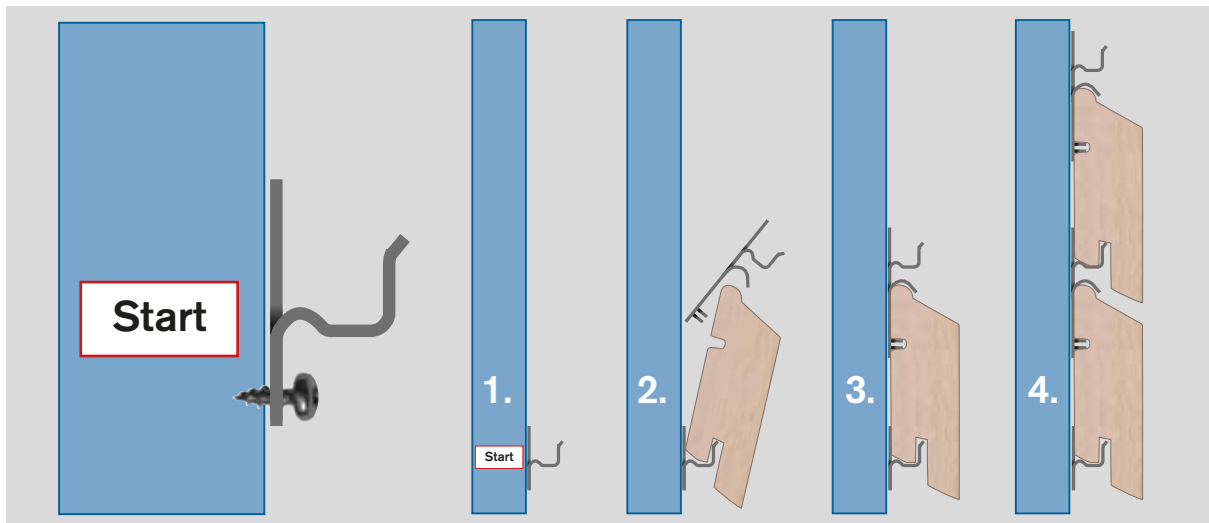

Fasten start clip on the lower edge and insert profile

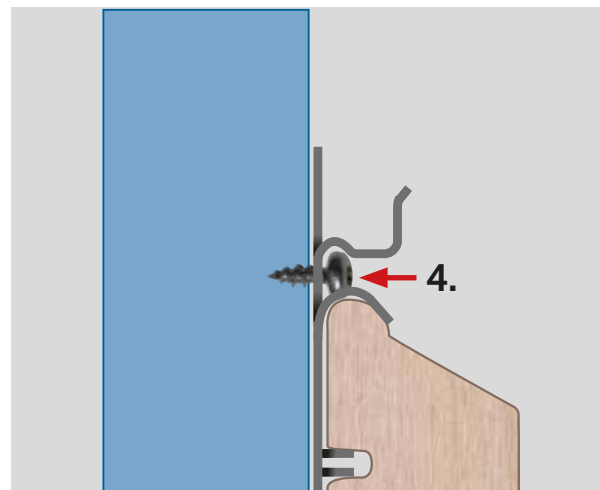
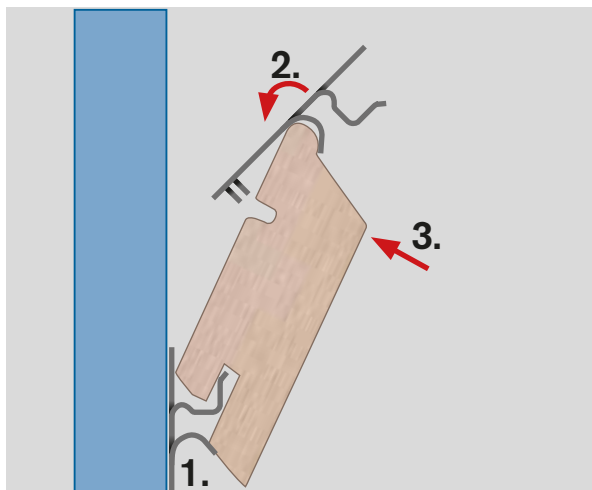

1. Fasten start clip on the lower edge and insert profile
2. Attach 2nd clip on the profile
3. Screw in profile towards lower edge

Screw clip on the lower edge

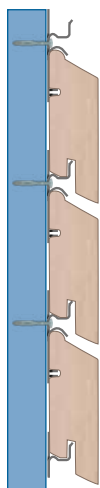

Repeat steps until complete assembly

5.4.3 Lintel formwork mounting (base-top)

Base and top profiles are usually installed vertically. Horizontal assembly is not recommended owing to inadequate drainage. Both the 90 mm profile as well as the 160 mm profile can be used as ceiling.

Product	Maximum lower edge spacing (centre/centre)	Joint	Fasteners
Casing board base (160 mm) and top (160 mm / 90 mm)	350 mm	> 5 mm	Suitable screw

Substructure / Protrusion

Lower edge distance maximum 350 mm

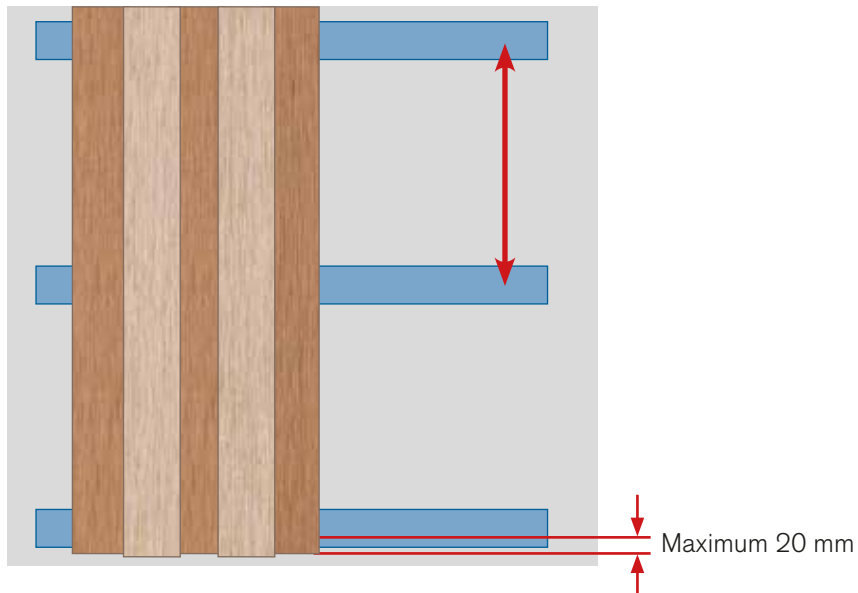

Protrusion to fastening point maximum 20 mm

Assembly of lintel formwork (base-top)

1. Base mounting

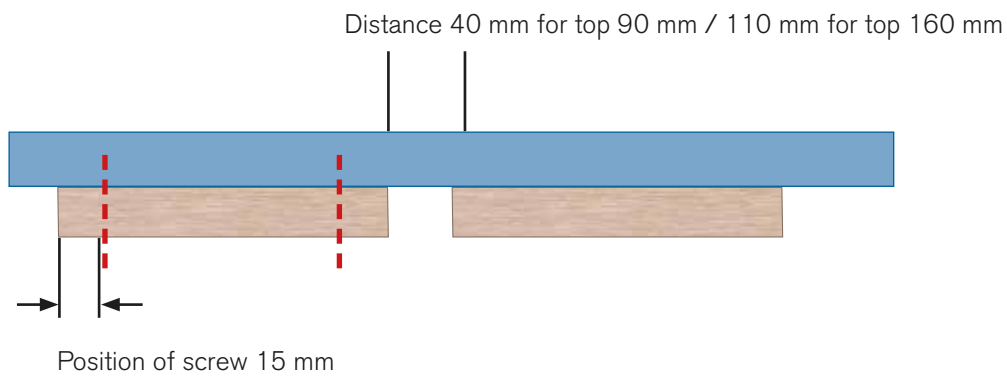

2. Top mounting

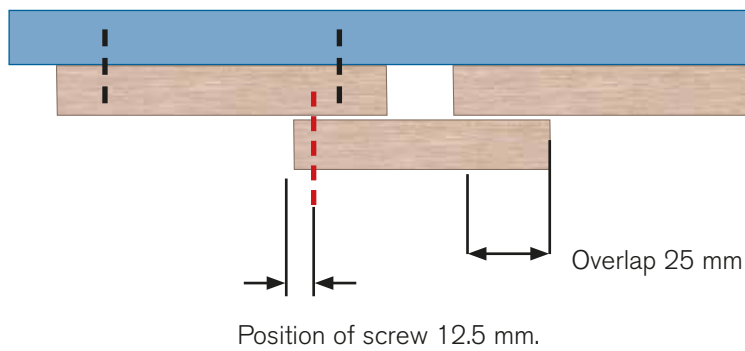

Joint in connection

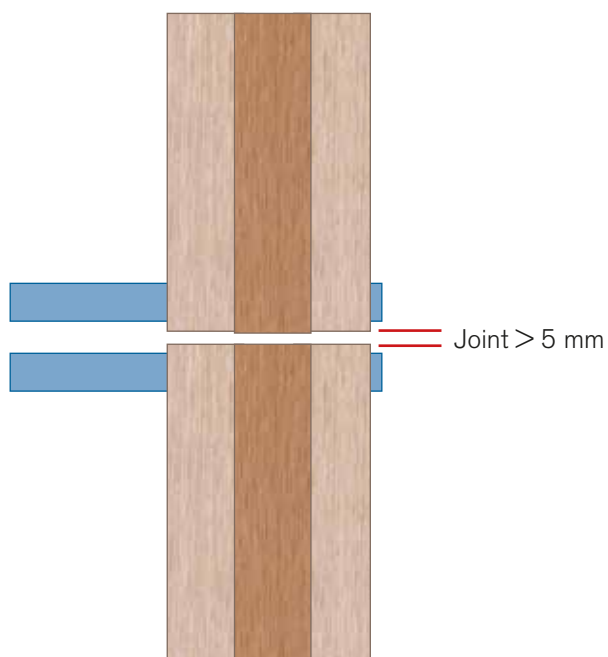

Note:

For base screw connection offset this slightly in height in order to avoid an overlap with the screw for the ceiling.

5.4.4. Tongue and groove mounting

Tongue and groove profiles can be installed horizontally and vertically. For visual reasons, a staggered layout is recommended for the joints.

Product	Maximum lower edge spacing (Centre/Centre)	Joint	Fasteners
Tongue and groove profile 140 x12	350 mm	approx. 3 mm recommended	Suitable screw

Substructure / Protrusion

Lower edge distance maximum 350 mm

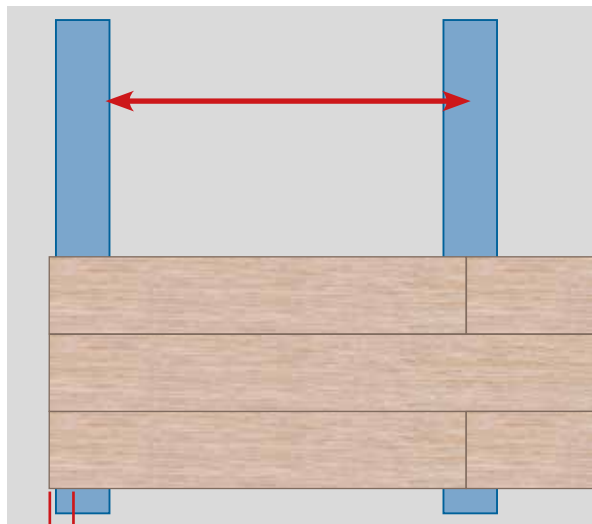

→ ← Protrusion to fastening point maximum 20 mm



Installation

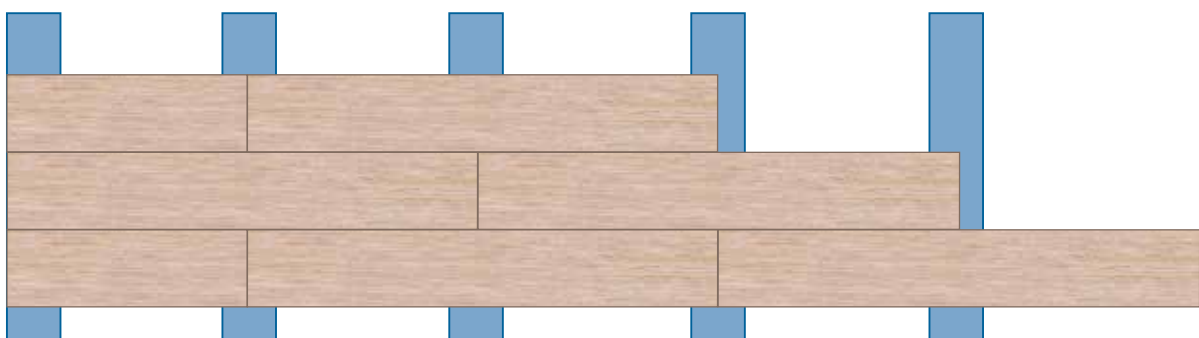
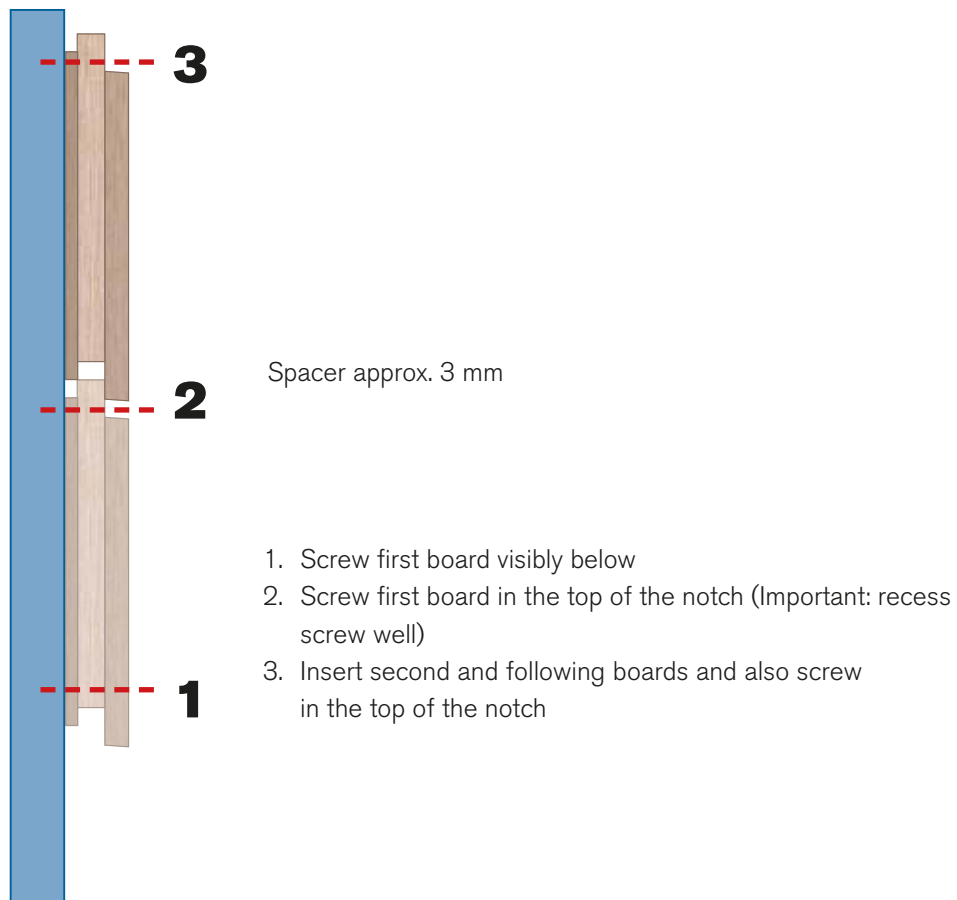

Bonded laying. We recommend the joints on the lower edge

Notes:

Ensure a straight alignment during assembly.
Maximum protrusion to the first fastening point 20 mm.

5.4.5 Clapboard mounting with overlap

Clapboards are generally installed horizontally. Vertical assembly is not recommended owing to inadequate drainage. For visual reasons and stability, a staggered layout is recommended for the joints. Shingles with various lengths can be combined here

Product	Maximum lower edge spacing (centre/centre)	Joint	Fasteners
Clapboard 600 x 300 x 8	275 mm	0 mm	Suitable screw
Clapboard 900 x 300 x 8			
Clapboard 1200 x 300 x 8			

Substructure / Protrusion

Lower edge distance 275 mm

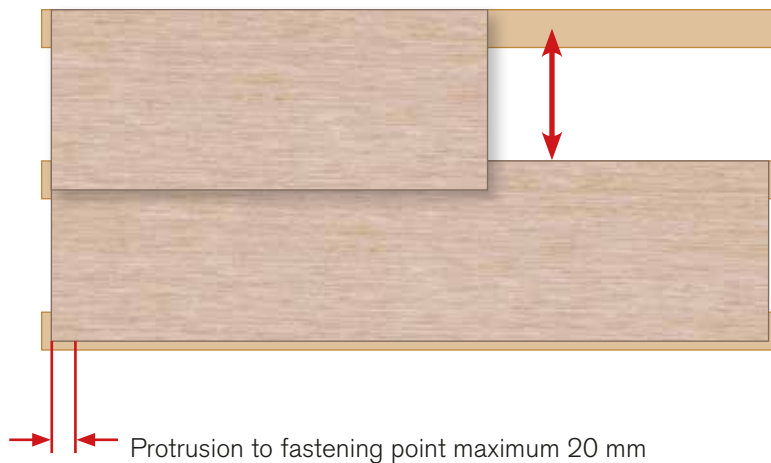

Notes:

We recommend a suitable wooden substructure for clapboards.
Adapted on one side to the resultant incline. (approx. 1.5°)

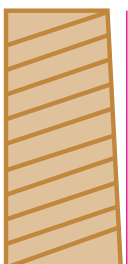

Installation

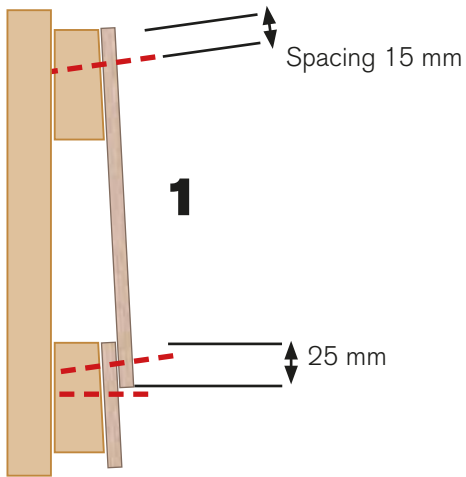

1. Mount strips of Resysta on the lower edge
2. Fasten first clapboard on the lower edge
3. Fasten clapboard below on the strip and lower edge (Edge / fixing distance – 15 mm)

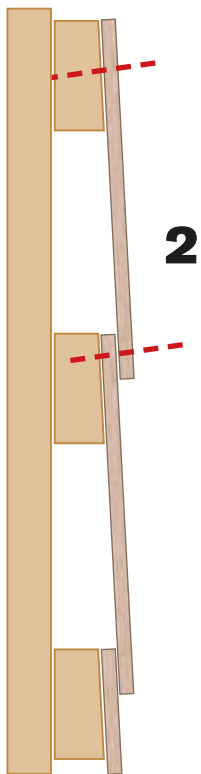

Attach further clapboards as follows

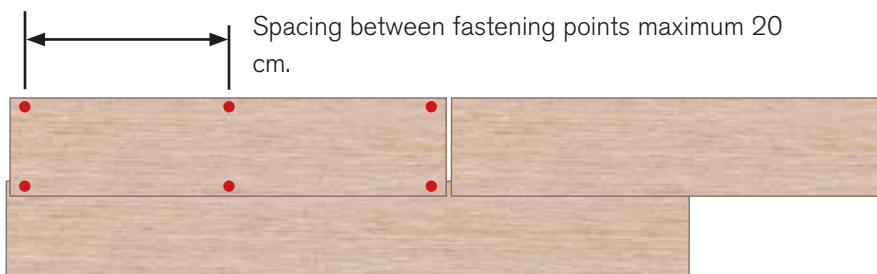

Notes:

Maximum protrusion to the first fastening point 20 mm.
Ensure a straight alignment during assembly.

5.4.6 facade board mounting

Strap 600 x 300 / 900 x 300 / 1200 x 300

Tongue and groove profiles can be installed horizontally and vertically.
For visual reasons, a staggered layout is recommended for the joints.

Product	Maximum lower edge spacing (centre/centre)	Joint	Fasteners
Facade board strap 600 x 300 x 12	300 mm + joint spacing	> 5 mm	Suitable screw
Facade board STRAP 900 x 300 x 12			
Facade board STRAP 1200 x 300 x 12			

Substructure / Protrusion

Lower edge spacing 300 mm + joint spacing

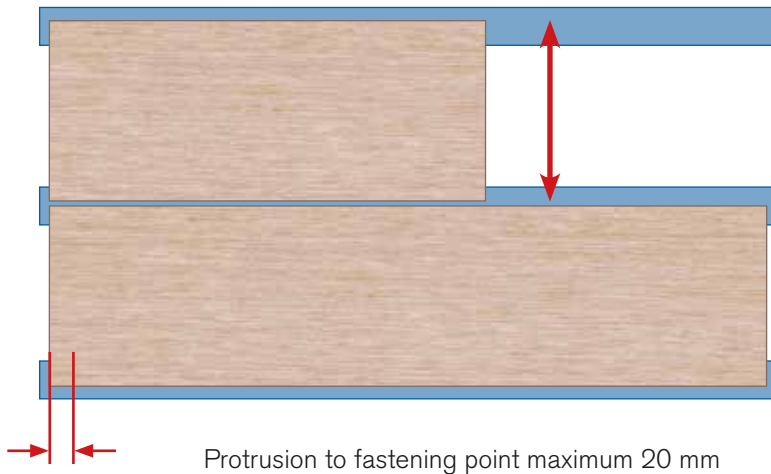

Installation

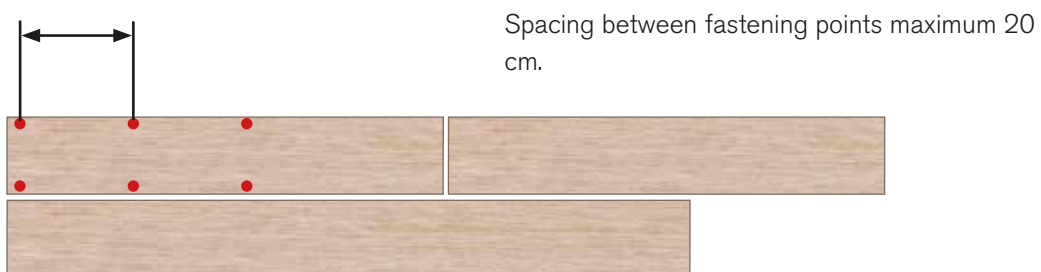
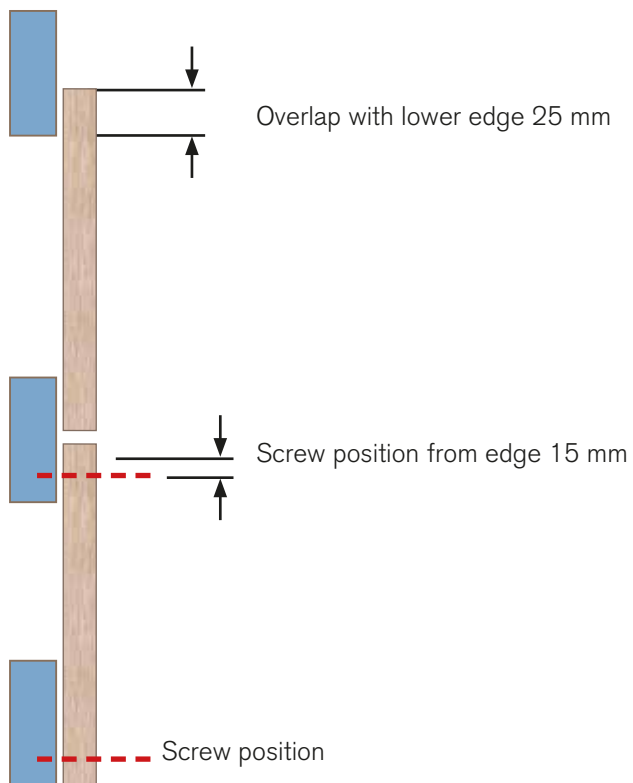

Notes:

Maximum protrusion to the first fastening point 20 mm.
Ensure a straight alignment during assembly.

5.5 Corner ends, window sills, connections

Corner ends, window sills etc. can be cut and made individually from Resysta UPB boards.

Diverse profiles such as corner profiles can typically be made by screwing or gluing.

Choose the fastening points corresponding to the material thickness during assembly to prevent sagging.

The protrusions should also be maximum 15 – 20 mm here.

6. CLEANING / CARE / REPAIR

6.1. Surfaces treated with 1-component RCL varnish

Care information:

The surface can be cleaned with mild standard household cleaners and water.

Faded, weathered or mechanically abraded surfaces can be freshened up again easily by renewed application.

Increased resistance:

To increase the mechanical resistance, it is possible to seal the surfaces additionally with RCL C00 clear varnish.

6.2. Surfaces sealed with RFS 2K varnish

Care information:

The surface can be cleaned with mild standard household cleaners and water.

If surfaces have been subject to high strain, we recommend renewing the surface sealing – depending on the extent of wear – before the varnish coating wears off. Expensive repair can be avoided in this way.

6.3. Information on use:

Sealers are subject to wear and tear. The individual service life depends on the layer thickness and the degree of stress. Abrasive stress may scratch the surface. A sophisticated appearance of the coating surface requires regular cleaning and maintenance. To increase UV resistance, we therefore recommend treating the surfaces beforehand with pigmented Resysta materials.

6.4. Repair information:

Scratched or mechanically worn surfaces can be freshened up again easily by renewed application of the material. Before reapplying, clean surfaces, sand slightly and remove sanding dust. The varnish or oil is applied as described in the working instructions.

7. FURTHER INFORMATION

Storage / Transport

- Store the boards horizontally on even and flat bases
- The pallet size should correspond to the board size when storing on pallets
The boards should not overhang, as they could otherwise deform
- Store in a dry place
- Avoid exposure to direct sunlight

Packing

- Protect from penetration by moisture
- Do not pack airtight (e.g. with films).

Disposal

The products can be recycled 100% without any problem and processed into new Resysta products.
The following specifications must be observed:

- Do not burn cut-offs, residual material and sanding dust
- If residual pieces accumulate, dispose of these properly
- Cut-offs and sanding dust can be collected and sent for recycling

For detailed questions regarding recycling, please contact your dealer, get in touch with **TREE PAL** or visit the Internet site: www.tree-pal.com



Vinyl Plus unterstützt das Resysta Recycling Konzept

8. LEGAL INFORMATION

UPB profiles and boards from Resysta do not have a building approval and are not suitable for supporting or structural purposes.

Approvals must be clarified with the authorities in individual cases.

The local building regulations must be observed.

The construction and mounting must be carried out according to the general state of the art and corresponding to the relevant application field and purpose.

Check the material for quality before installation.

Observe all current standards and regulations.

Fire behaviour: The requirements in respect to flammability depend on the relevant regulations and the required fire behaviour. TREE PAL profiles are normally flammable as standard.

The information and data contained here is deemed to be correct and has been obtained from sources regarded as reliable. Resysta International GmbH gives neither explicit nor implicit assurances of any kind in respect to the correctness or completeness of the information and data contained here.

Resysta International GmbH is not liable for claims arising from use of or trust in the information and data contained here, irrespective of whether the claim is based on this information and data being incorrect, incomplete or misleading in any other way. It only serves for evaluation, examination and checking by the user. On account of possible technical modifications, it is the responsibility of the user to obtain the latest information.

Products of Resysta International GmbH/TREE PAL are manufactured for professional and industrial processors as well as for experienced DIY enthusiasts with basic knowledge of the trade. The working instructions provided in this procedure are to be regarded as non-binding recommendations and do not represent any liability whatsoever. These recommendations are based on our experience and test series and are intended to facilitate and assist the work of our buyers. Any potential deviation from the ideal work conditions is the responsibility of our buyers and can effect the (end) result of the application. However, this does not exempt buyers from their obligation to check the product and its suitability for their project, preferably by a trial working. In all cases of doubt regarding the handling or working of the purchased product, our material advisors or application and laboratory technicians will be pleased to provide information to the best of their knowledge. Resysta International GmbH/TREE PAL of course guarantees a defect-free quality of its products according to the relevant product specifications, but the responsibility for use of the products supplied lies solely with the buyer. Unless we have assured specific properties and suitability of the products for a contractually agreed intended use explicitly and in writing, technical application advice or consultation, even if provided to the best of the giver's knowledge, is non-binding in all cases and does not represent any guarantee whatsoever. Resysta International GmbH/TREE PAL is liable for the application of its products by its buyers in accordance with its Terms and Conditions of Business, to which the user's attention is drawn. The current assembly information and technical information sheet can be ordered on request or is available for downloading from www.tree-pal.com. The validity of the previous editions expires upon publication of the new edition.

As at: 2018-12-15

Water-resistant panel with the natural look & feel of wood
UPB® BOARDS made of (Re)systa®

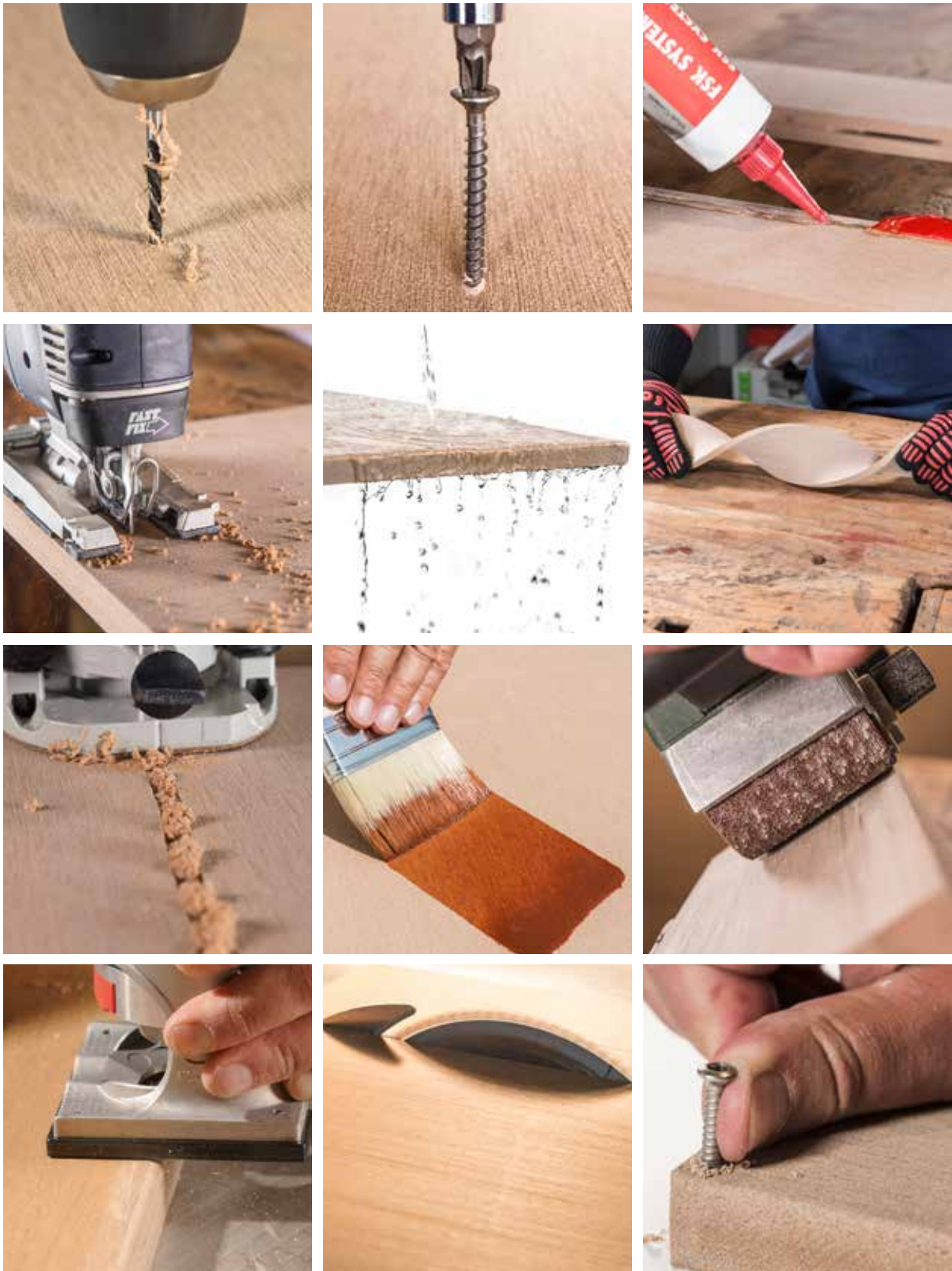

Version April 2019 | International

TREE PAL Middle East Headquarters

A brand of Resysta International GmbH | Tamouh Tower, Marina Square, Al Reem Island | Abu Dhabi, U.A.E. | info@tree-pal.com | www.tree-pal.com | UPB Service Hotline: +971-2-4170515